

▼ FF-120



- Makes refacing easy – hand operated machine tool can be set up anywhere without the need for air, electric or hydraulic power
- Lightweight and portable (15 kg in storage box)
- Adjustable cutting head for reface of flat flange surfaces of pipes with flange outside diameter facing range 25,4 - 304,8 mm [1 - 12 inch]
- Interchangeable collets for ID mounting range 25,4 - 152,4 mm [1-6 inch] allow the user to work on many different flanges with minimal time between set-ups
- Interchangeable lead screws suitable for refacing damaged raised-face (RF), flat-face (FF) or lens-ring joint flanges
- Tool body with expanding collets centers itself providing real concentric operation.

▼ The Enerpac FF-120 used to face a pipe flange.



## Safe, efficient and accurate refacing of flat pipe flange surfaces



### Complete in Wheeled Carrying Case

The FF-120 comes as portable set (15 kg). Can be transported, easy set-up and operated by a single

technician. Set includes:

**FFL-kit** with locators, O-Rings and extensions;  
**FSS-kit** with feed screw and nut ½”-20 UN for surface roughness Ra 1,6 - 2,4 μ.

**FSF-kit** with feed screw and nut ½”-11 UNF for surface roughness Ra 3,2 - 6,3 μ.



### Joint Separation Tools

FS and FSH-Series parallel wedge spreaders provide quick and easy joint separation using hydraulic or mechanical force.

Page: 228



### Flange Alignment Tools

The ATM-Series provide safe and high-precision flange alignment tools that fit most commonly used ANSI, API, BS and DIN flanges.

Page: 230



### Controlled Tightening and Loosening

Use Enerpac Bolting Tools to seal the joint to the precise torque or tension required:

torque multipliers, torque wrenches and hydraulic bolt tensioners.

Page: 177

# QuickFace – Mechanical Pipe Flange Face Tool



## Mechanical Flange Face Tool

Portable, hand powered tool makes even the hardest to reach pipe flanges resurface-able in a safe and convenient way.

### Makes refacing easy

A simple and cost effective solution – the FF-120 turns a two man operation with heavy equipment, compressors and portable generators into a one man job.

The FF-120 has interchangeable lead screws that make it suitable for resurfacing damaged flat-faced, raised-face or lens-ring joint flanges to the high safety standards required. After selecting the correct lead screw for the operation, the tool body is inserted in the pipe end and centres itself with adjustable locators to provide real concentric operation.

The tool arm is then rotated by hand using a worm-gear mechanism to provide a perfect spiral “gramophone” finish. The tool can be adjusted with a calibrated slide to define cut depth and the correct finish.

### Surface finish & accuracy

A serrated finish with 30-55 grooves per inch and a resultant roughness of between Ra 3,2-12,5  $\mu$  (125-500 micro inches). The FF-120 has same precision and quality of finish as a lathe.

### Cost effective solution

Small and portable enough to be a permanent addition to your equipment range, Enerpac’s FF-120 is the perfect solution to all of your small diameter facing problems.

## FF Series



Pipe Flange Cutting Diameter Range:

**Ø 25-305 mm / 1-12"**

Internal Pipe Mounting Range:

**Ø 25-152 mm / 1-6"**

Cutting Resultant Roughness:

**Ra 3,2 - 12,5  $\mu$**



- 1 Hand-operated cold work tool – no need for external power and hot work permits.
- 2 Calibrated cross slide for accurate cutting control.
- 3 Adjustable cutting head for reface of flat flange surfaces of pipes with flange OD facing range  $\varnothing$  25,4-304,8 mm [1-12 inch].
- 4 Interchangeable lead screws enable selection of surface finish between Ra 3,2-12,5  $\mu$ .
- 5 Utilizes standard 3/8 inch or 10 mm tool steel.
- 6 Range of interchangeable collets allow the tool to accommodate  $\varnothing$  25,4 - 152,4 mm (1 - 6 inch) pipe ID.
- 7 Tool body with expanding collets centers in the bore ensuring concentric and accurate set-up.

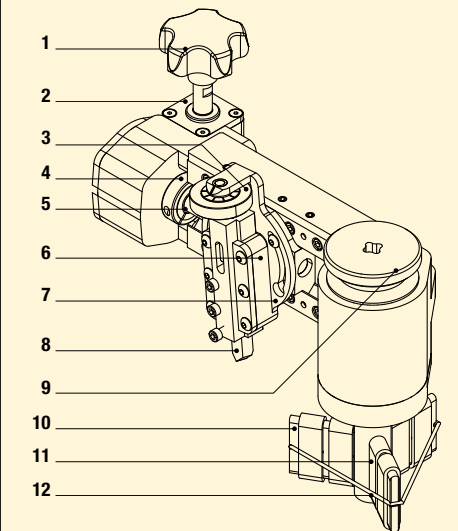

- |  |                        |
|--|------------------------|
| 1 Feed Knob  | 6 Tool Block           |
| 2 Gear Box   | 7 Swivel Slide         |
| 3 Cutting Depth Adjustment with indicator: 0,127 mm (.005 inch) per mark | 8 HSS 3/8" Tool Bits   |
| 4 Locking Collar   | 9 Mandrel Locking Knob |
| 5 Lead/Feed Screw  | 10 Locator Extensions  |
|  | 11 Adjustable Locators |
|  | 12 O-Ring              |

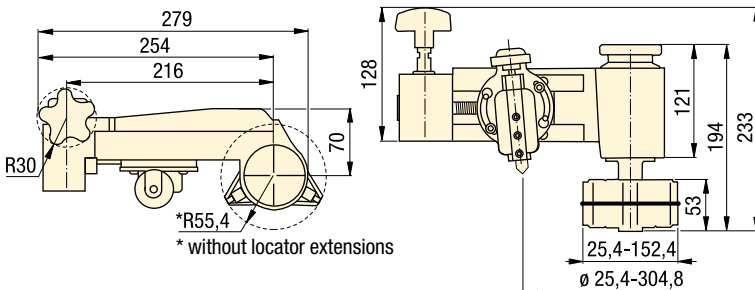

### SELECTION CHART

Pipe Flange Cutting Diameter Range		Internal Pipe Mounting Diameter Range		Cutting Resultant Roughness	Model Number	Weight (kg)
(mm)	(inch)	(mm)	(inch)			
25,4 - 304,8	1,0 - 12,0	25,4 - 152,4	1,0 - 6,0	3,2 - 12,5	FF-120	6,8

▼ The Enerpac FF-120 QuickFace has same precision and quality of finish as a lathe.

